

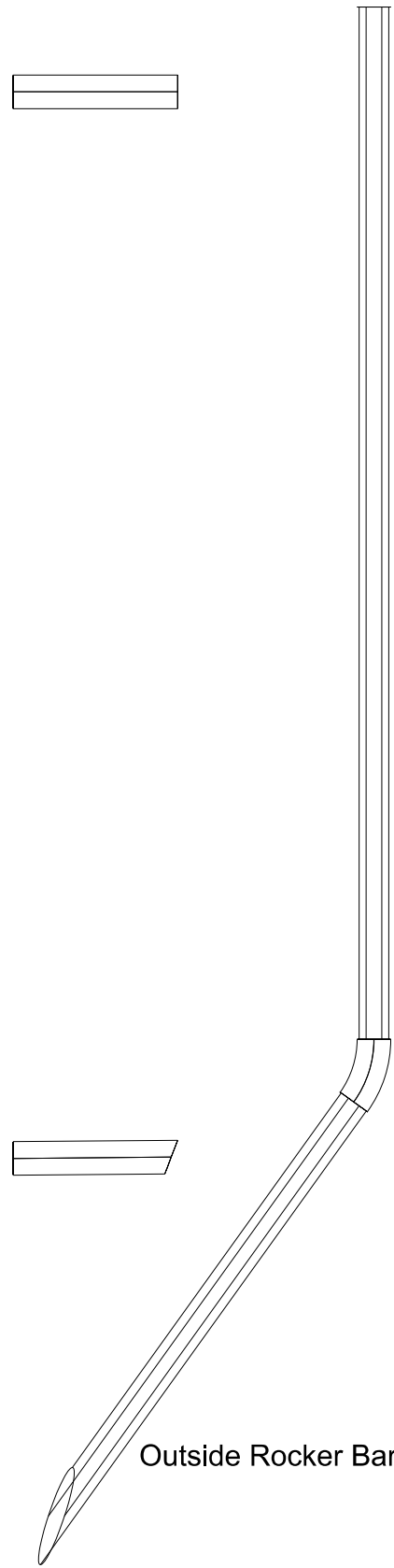

Inside Rocker Bars



Outside Rocker Bar

0 1
SCALE
1" = 1"

Project Name F1 Chassis	ROCKERS	Figure 1
----------------------------	---------	----------

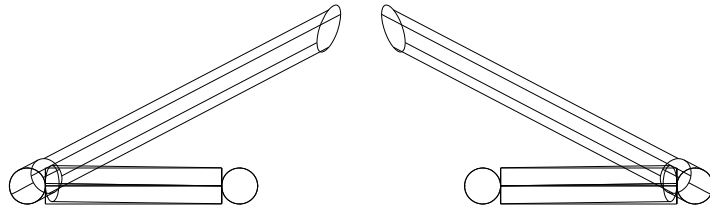
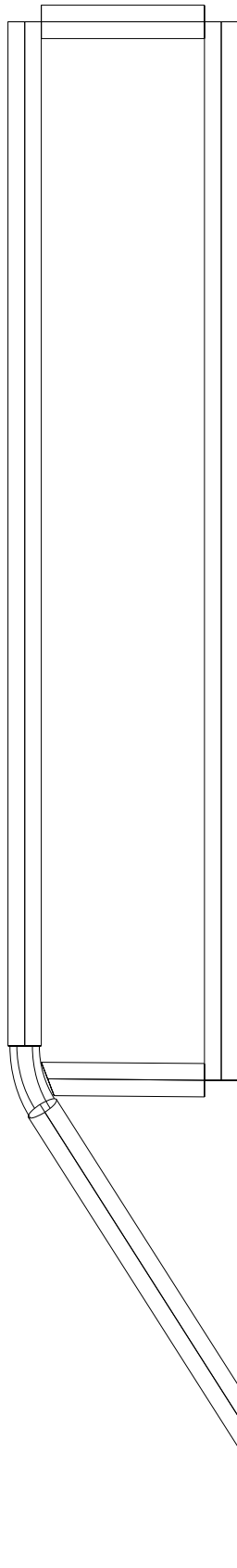

Front view of assembled tubes
Note the angle of the outside bar

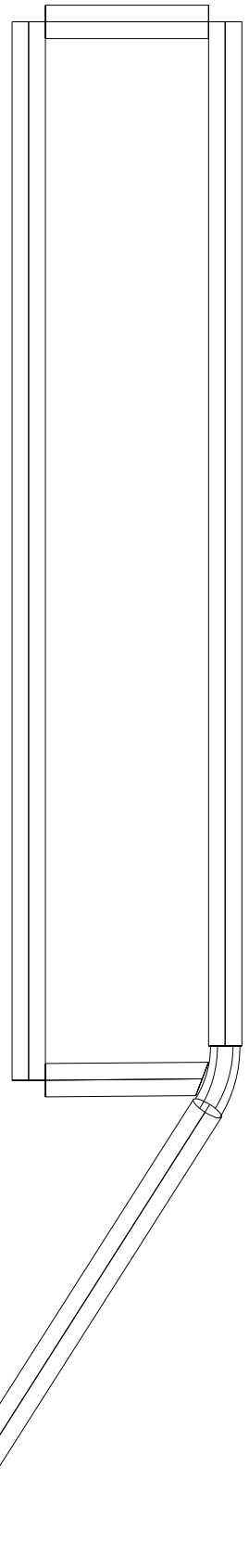

Top view of assembled tubes

0 1
SCALE
1" = 1"

Project Name F1 Chassis	ROCKERS	Figure 2
----------------------------	---------	----------

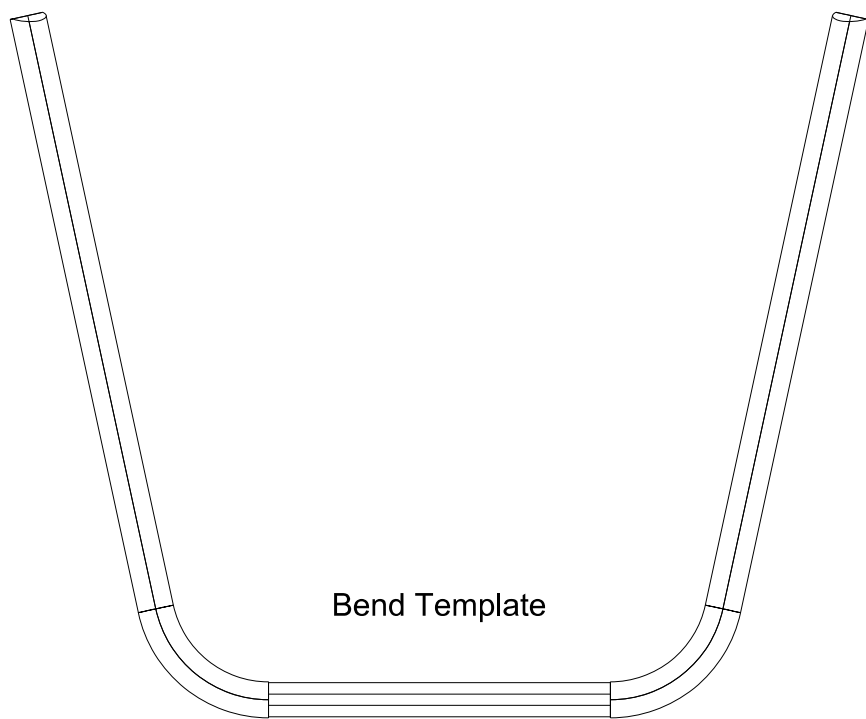
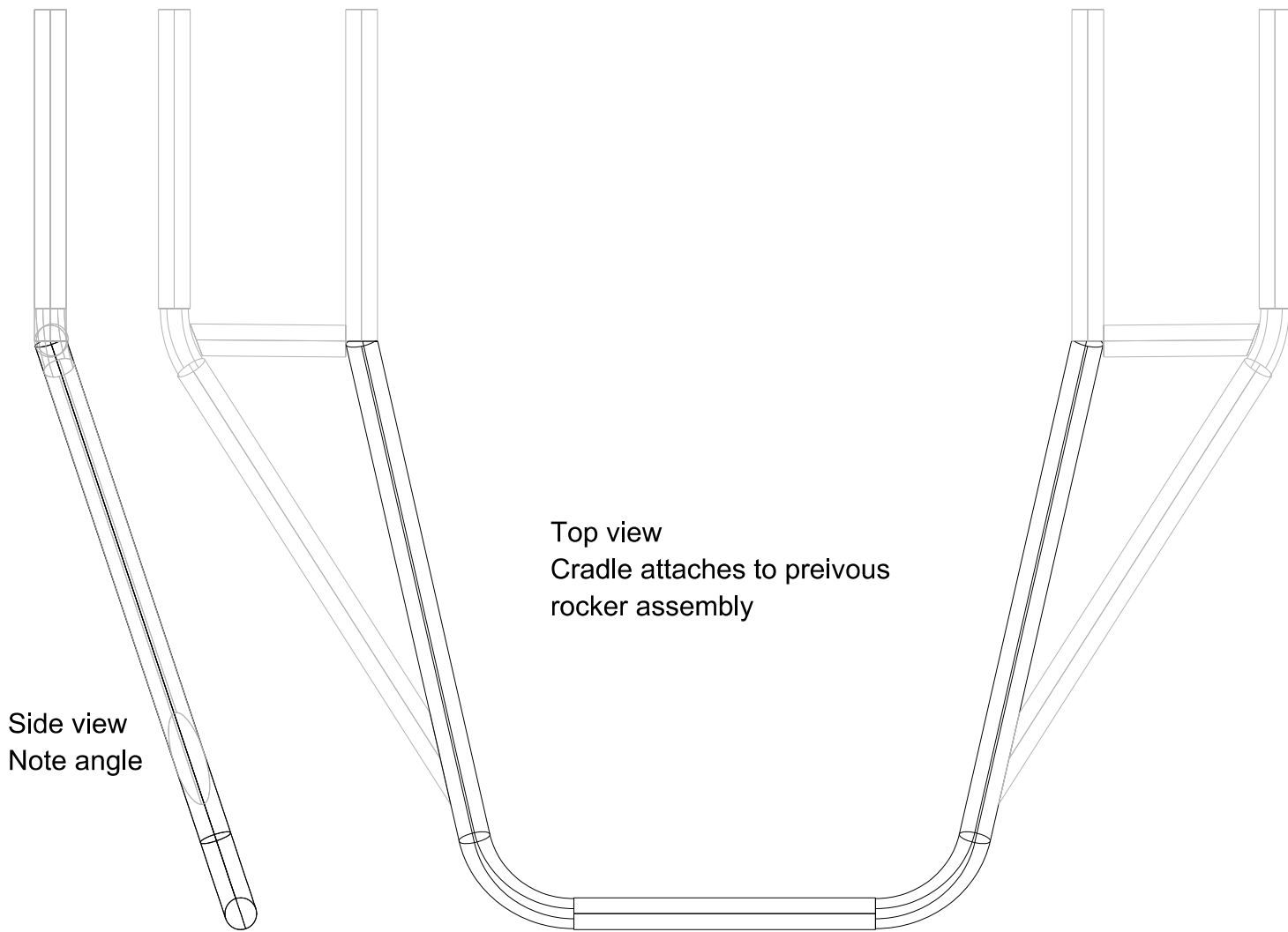

0 1
SCALE
1" = 1"

Project Name F1 Chassis	LOWER CRADLE	Figure 3
----------------------------	--------------	----------

Rear

Side view
Note angle

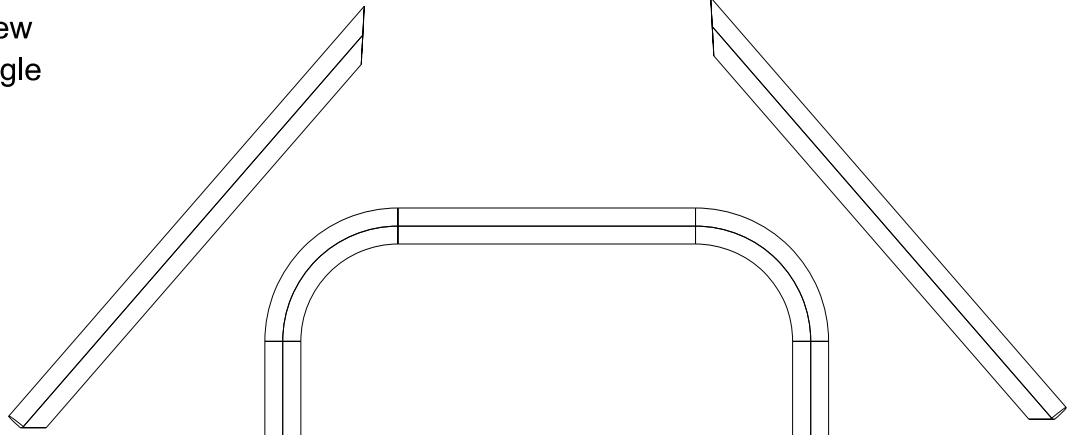

Front

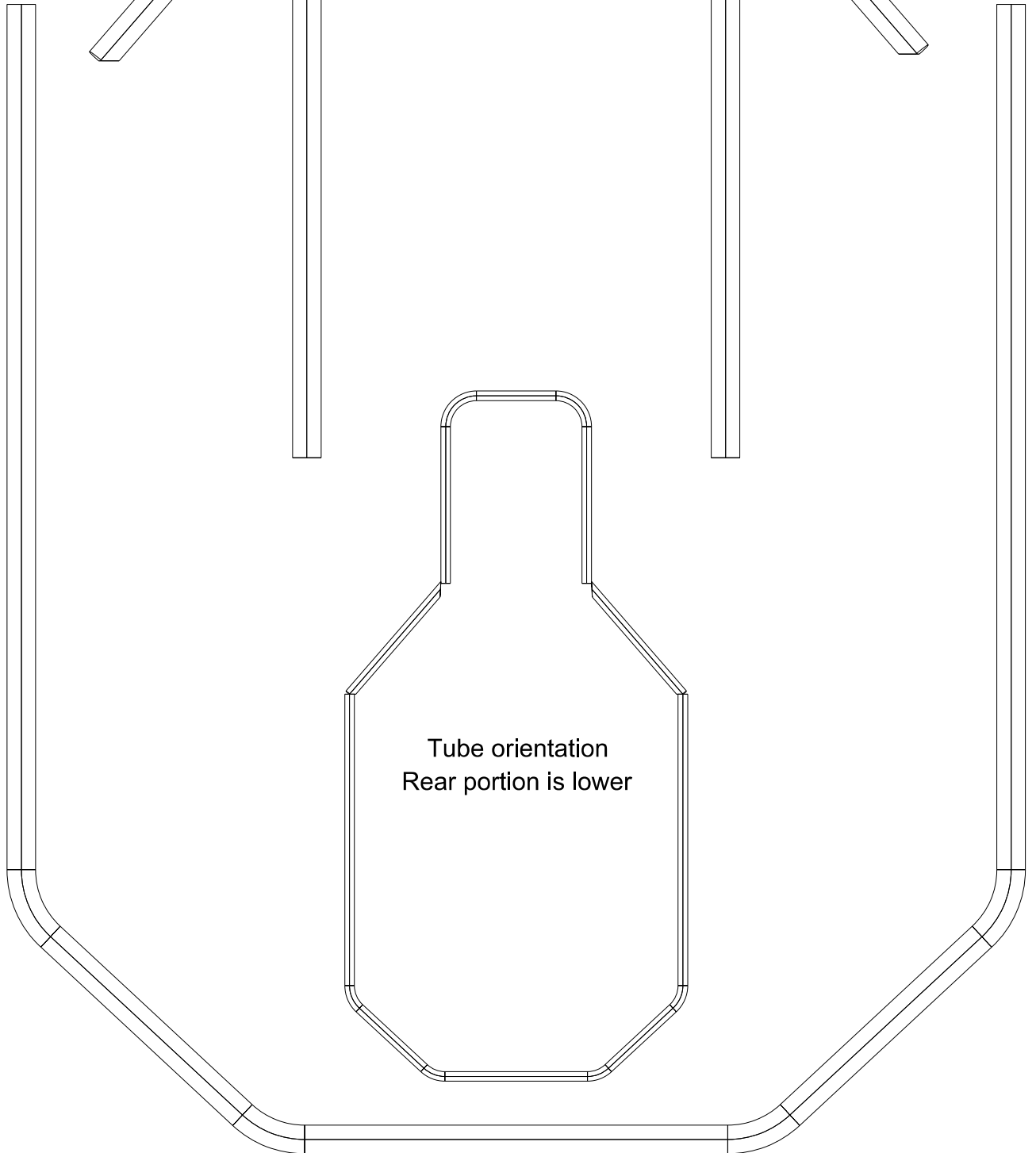

Tube orientation
Rear portion is lower

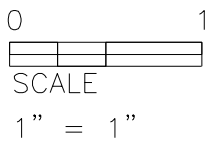

Project Name
F1 Chassis

BELT LINE

Figure 4

RATHER THAN ATTEMPTING COMPLEX BENDS, I HAVE CUT THE A TO C TUBE BETWEEN THE TWO BENDS TO MAKE REPLICATION OF THE TUBE EASY.

THE ROTATION OF THE TWO TUBES IS SHOWN IN THE INSET. HOWEVER, YOU CAN TACK THEM IN PLACE ON THE CHASSIS BEFORE WELDING THEM TOGETHER TO SET THE ROTATION.

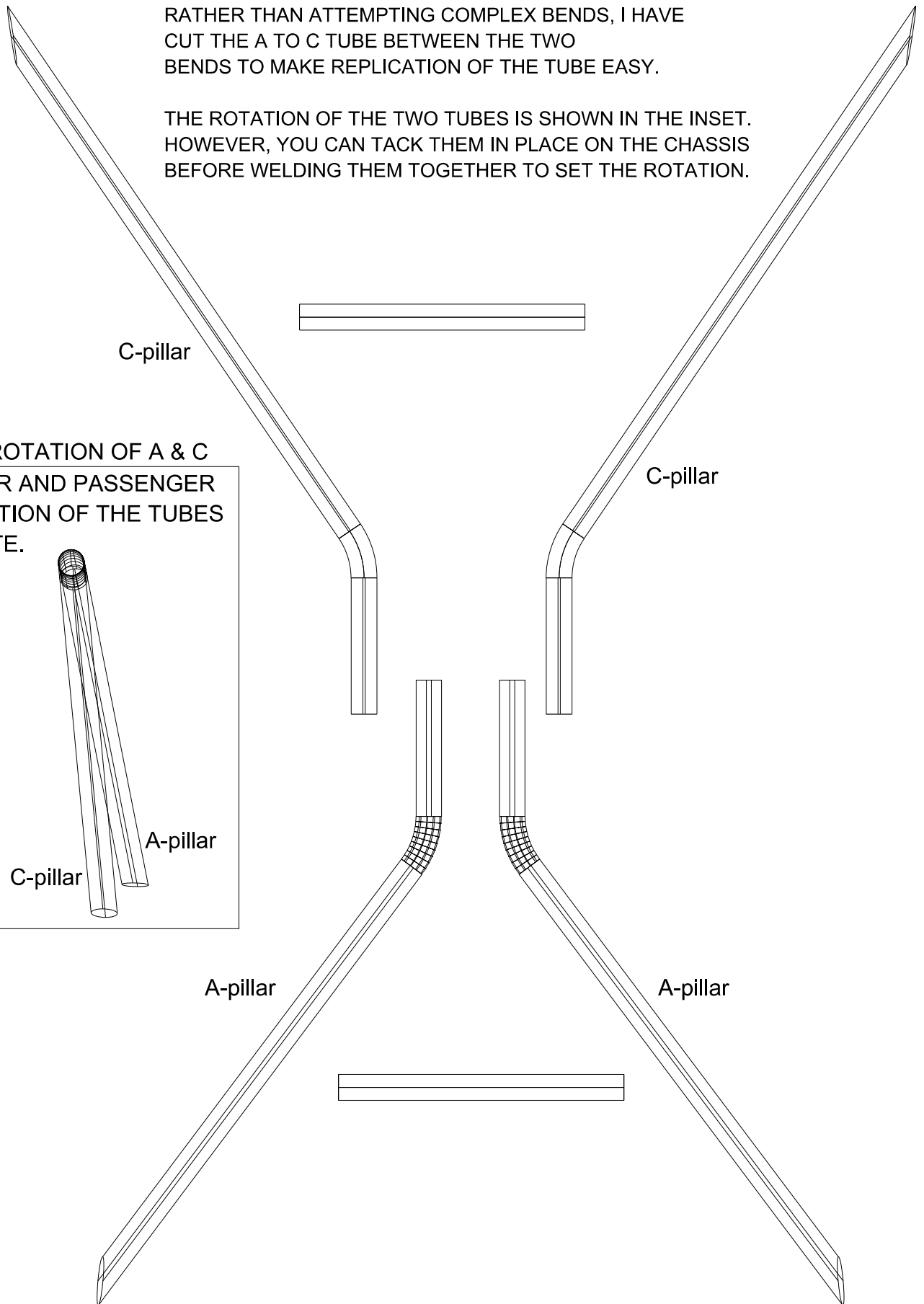

INSET - ROTATION OF A & C
THE DRIVER AND PASSENGER
SIDE ROTATION OF THE TUBES
IS OPPOSITE.

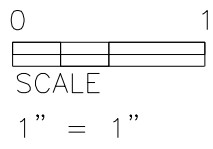
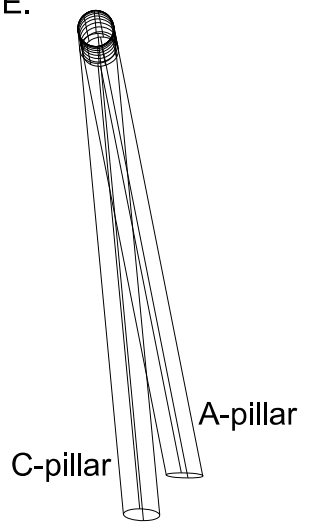

Project Name F1 Chassis	CAB	Figure 5
----------------------------	-----	----------

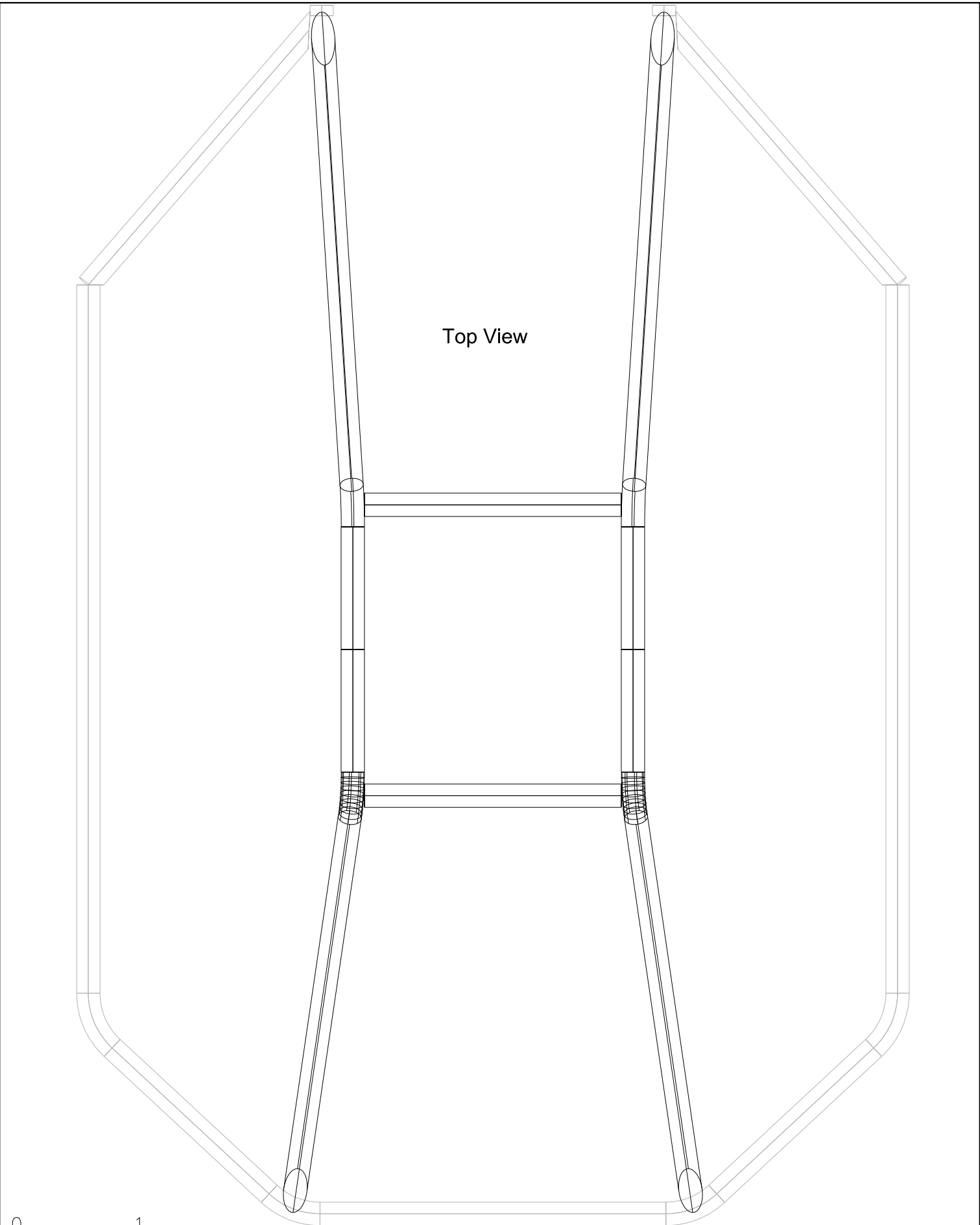

Top View

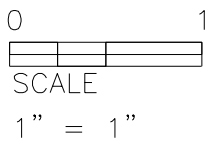

Project Name
F1 Chassis

CAB PLACEMENT

Figure 6

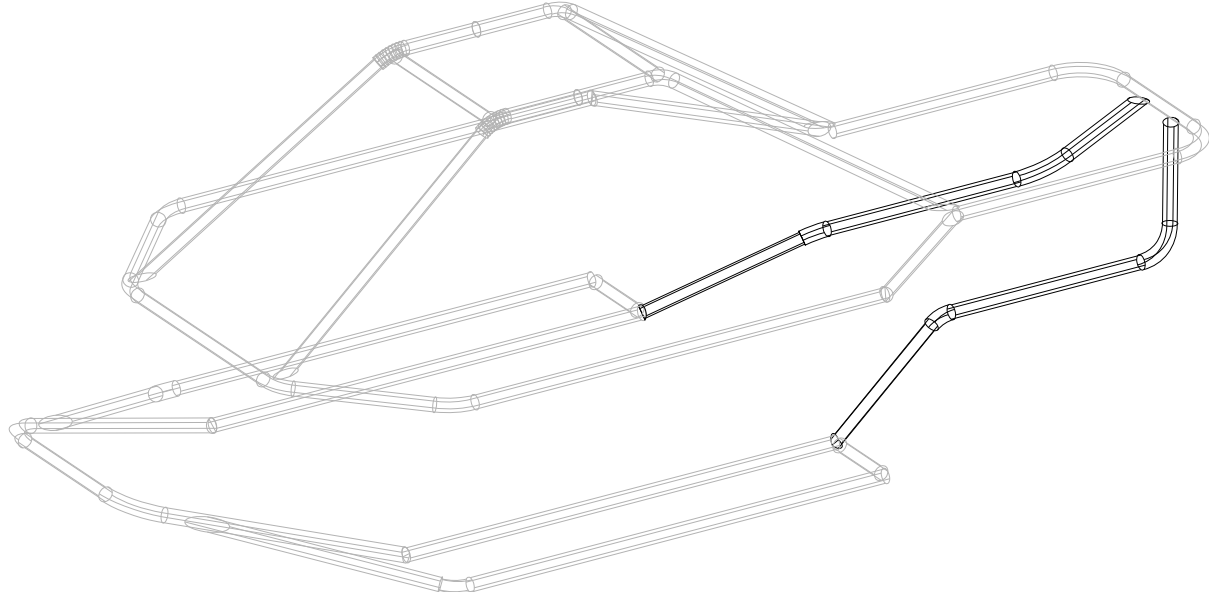
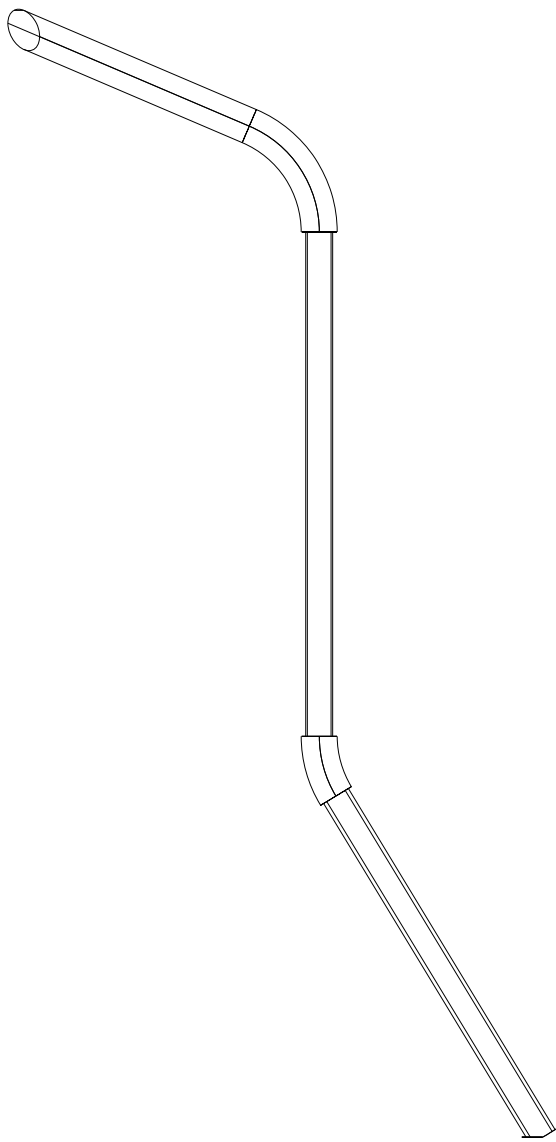
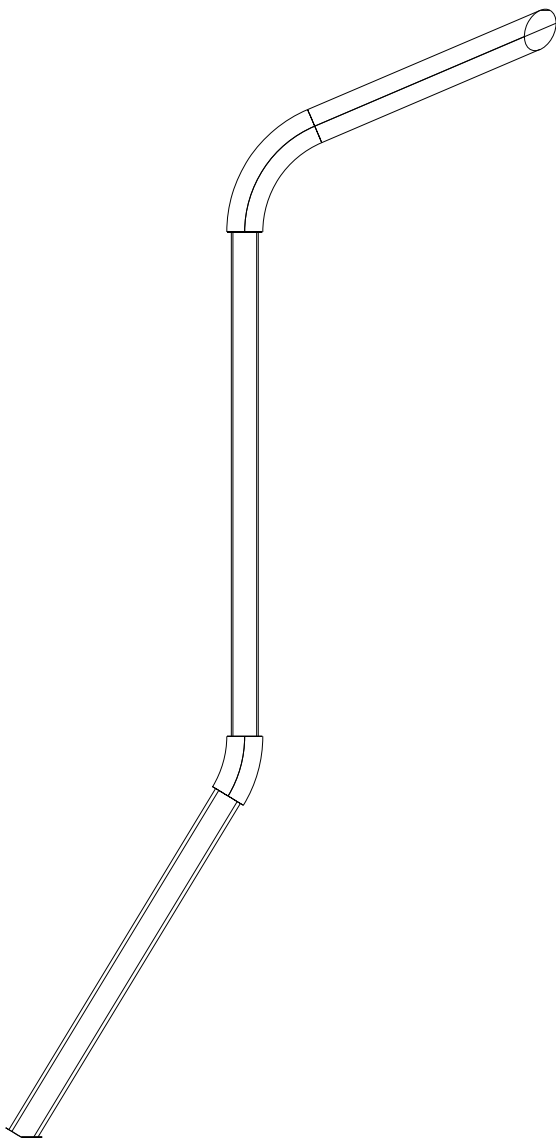

0 1
SCALE
1" = 1"

Project Name F1 Chassis	REAR LOWER RAILS	Figure 7
----------------------------	------------------	----------

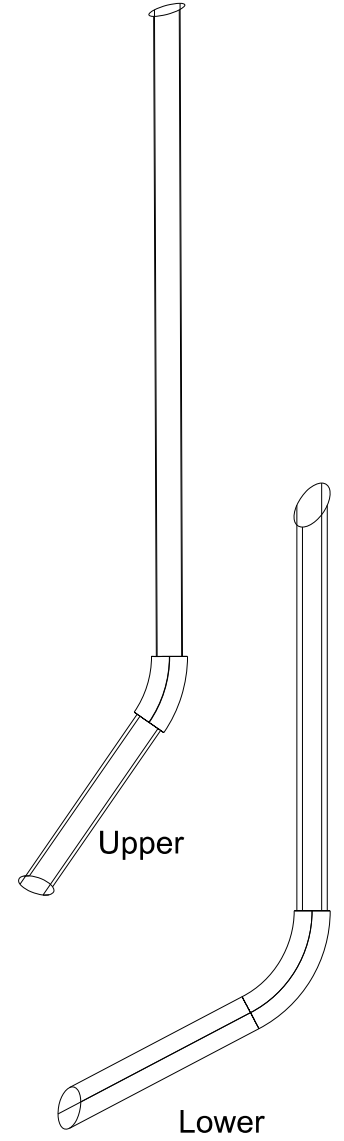
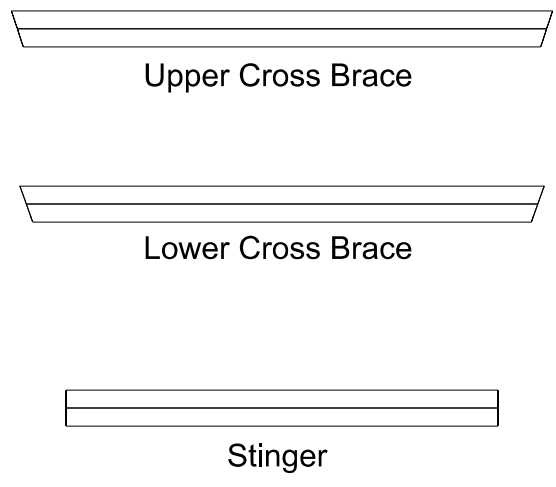
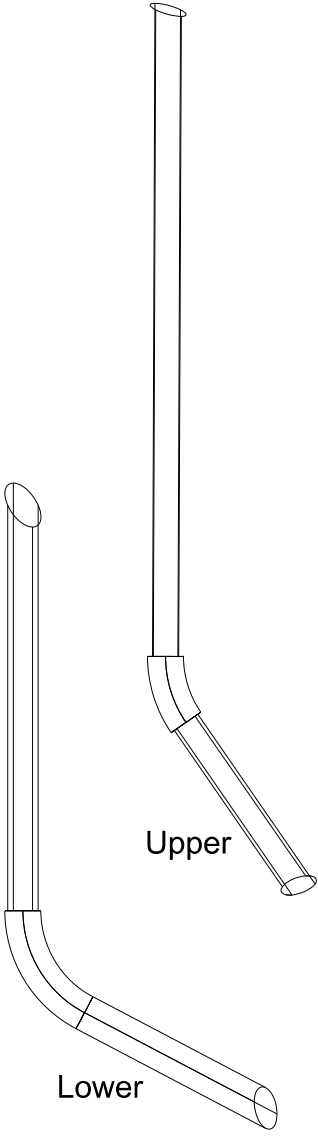

0 1
SCALE
1" = 1"

Project Name F1 Chassis	NOSE	Figure 8
----------------------------	------	----------

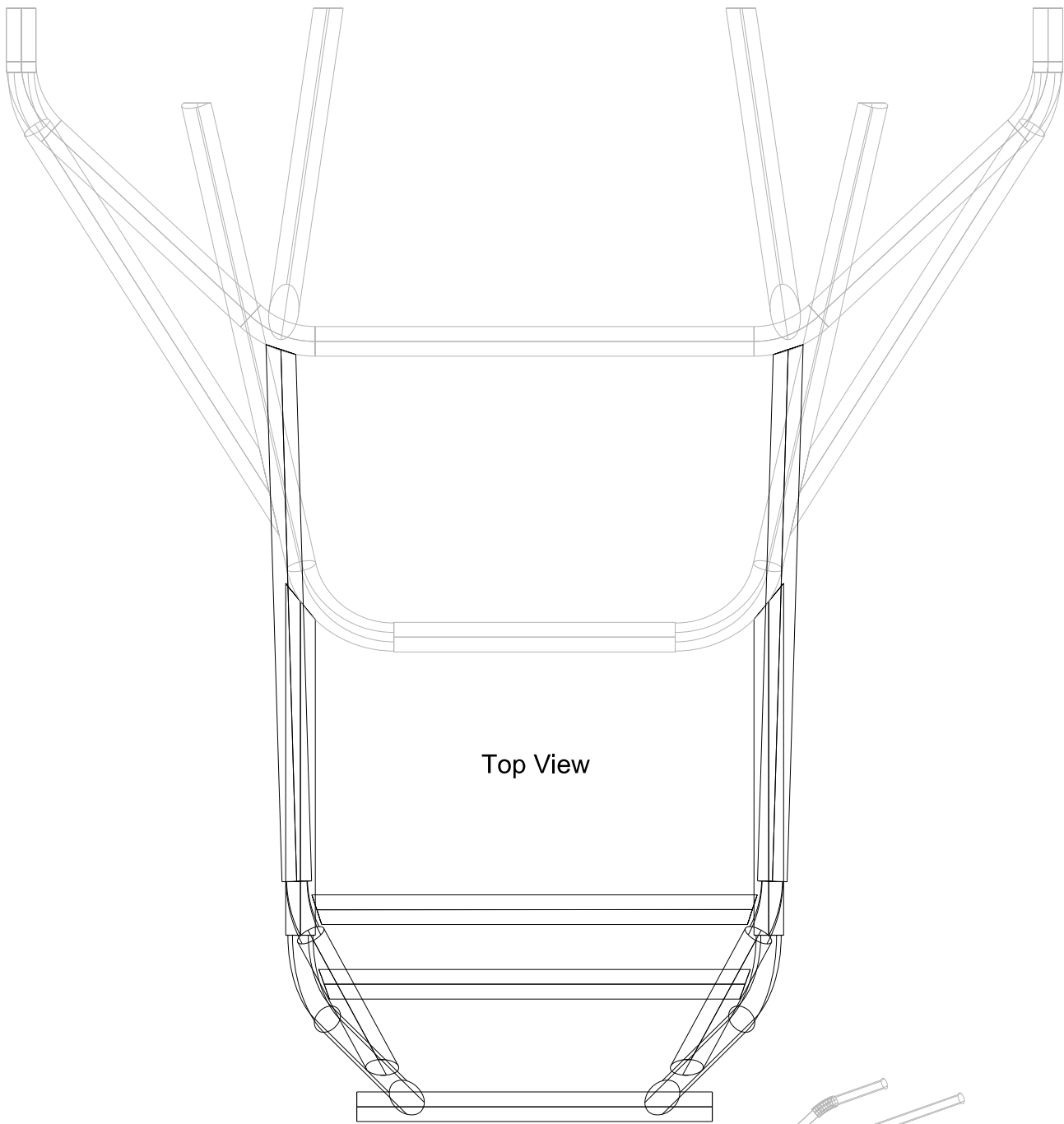

Top View

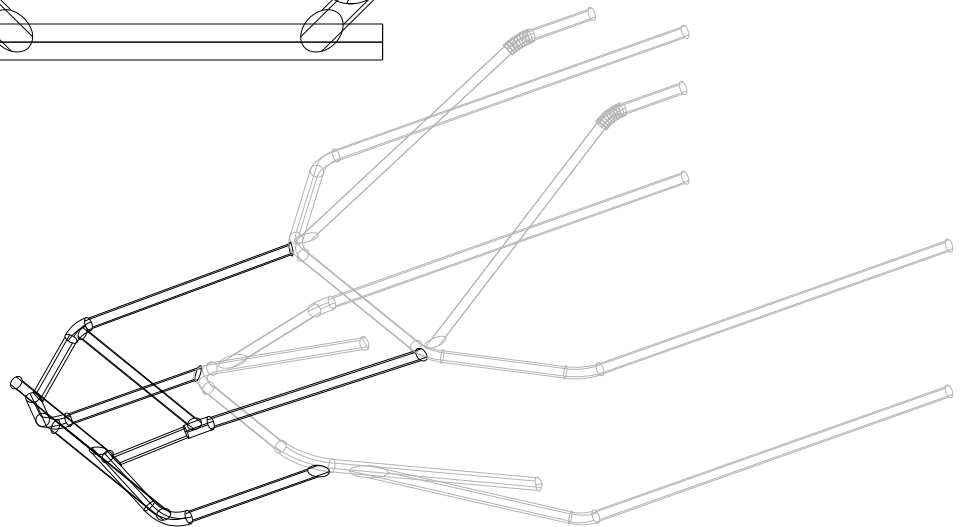

0 1
SCALE
1" = 1"

Project Name
F1 Chassis

NOSE ASSEMBLY

Figure 9

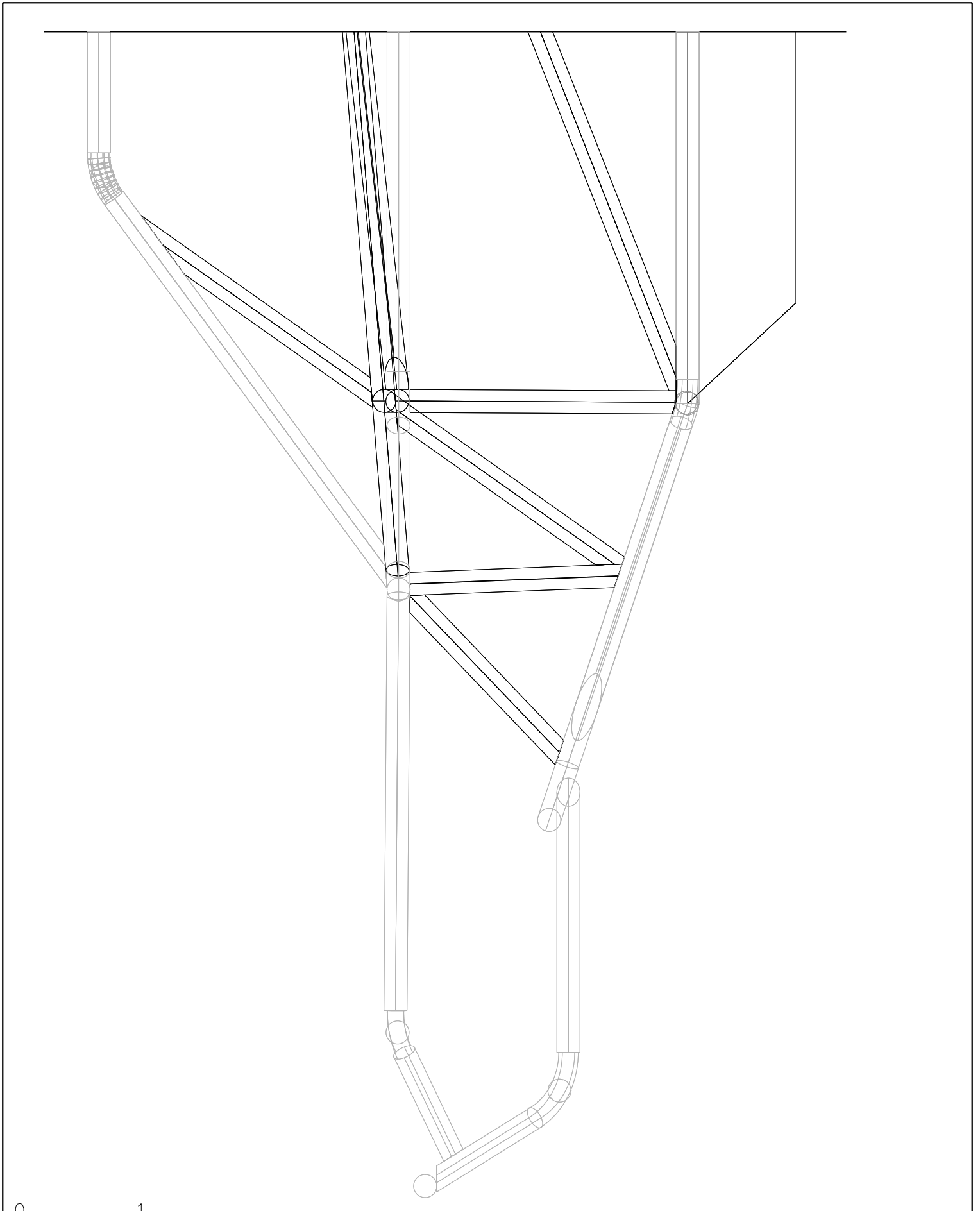

0 1
SCALE
1" = 1"

Project Name F1 Chassis	SIDE VIEW FRONT	Figure 10
----------------------------	-----------------	-----------

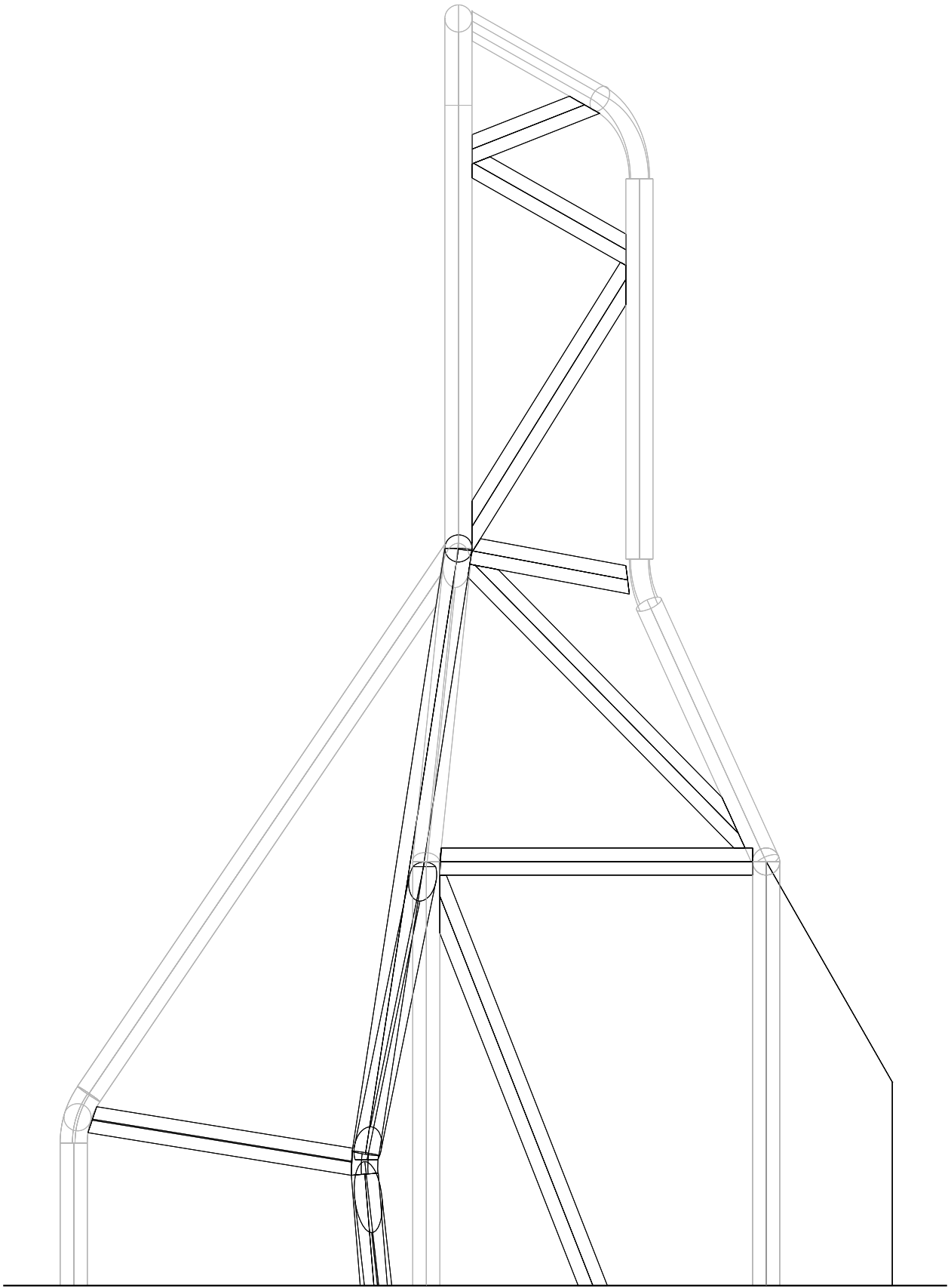

0 1
SCALE
1" = 1"

Project Name
F1 Chassis

SIDE VIEW REAR

Figure 11

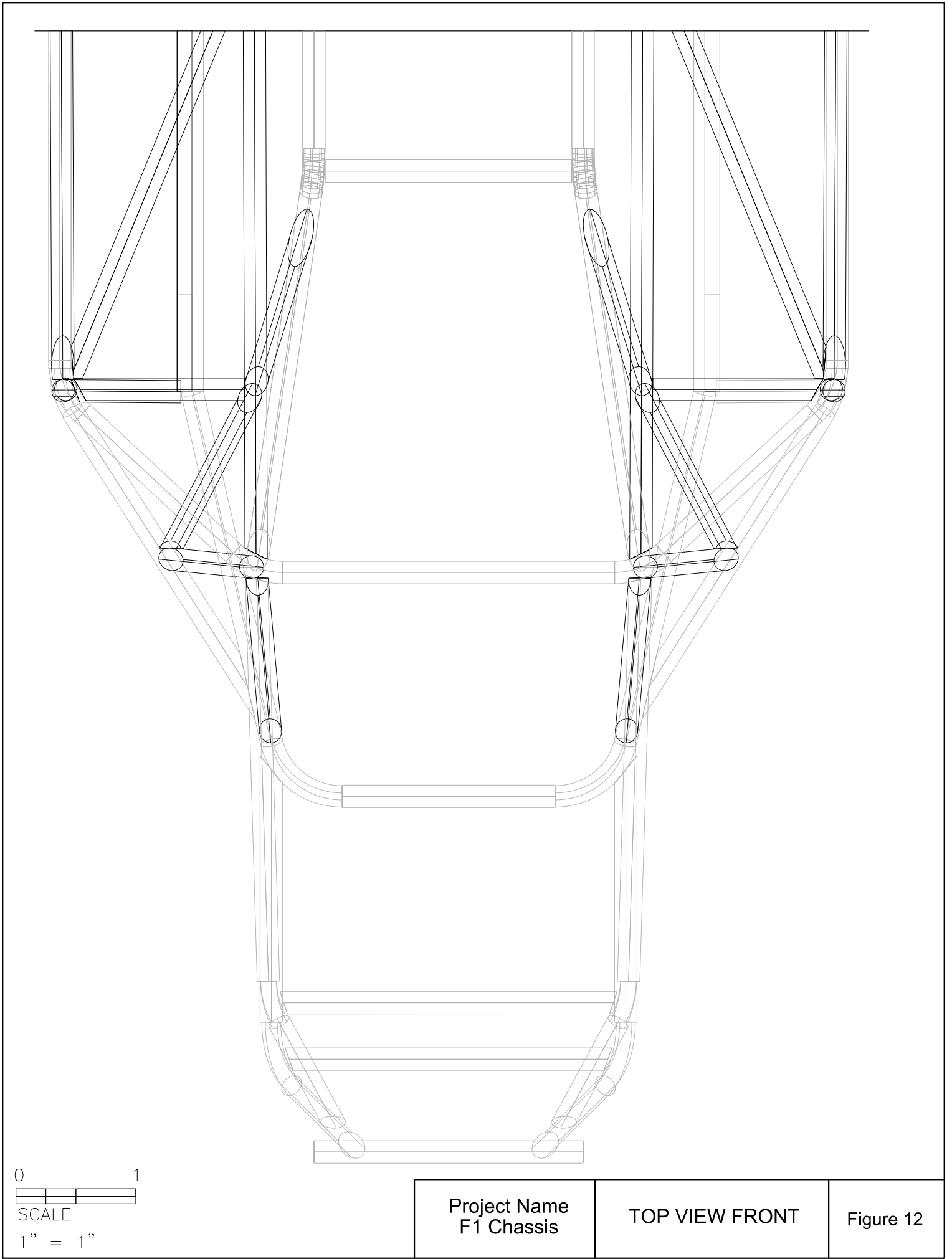

0 1
SCALE
1" = 1"

Project Name
F1 Chassis

TOP VIEW FRONT

Figure 12

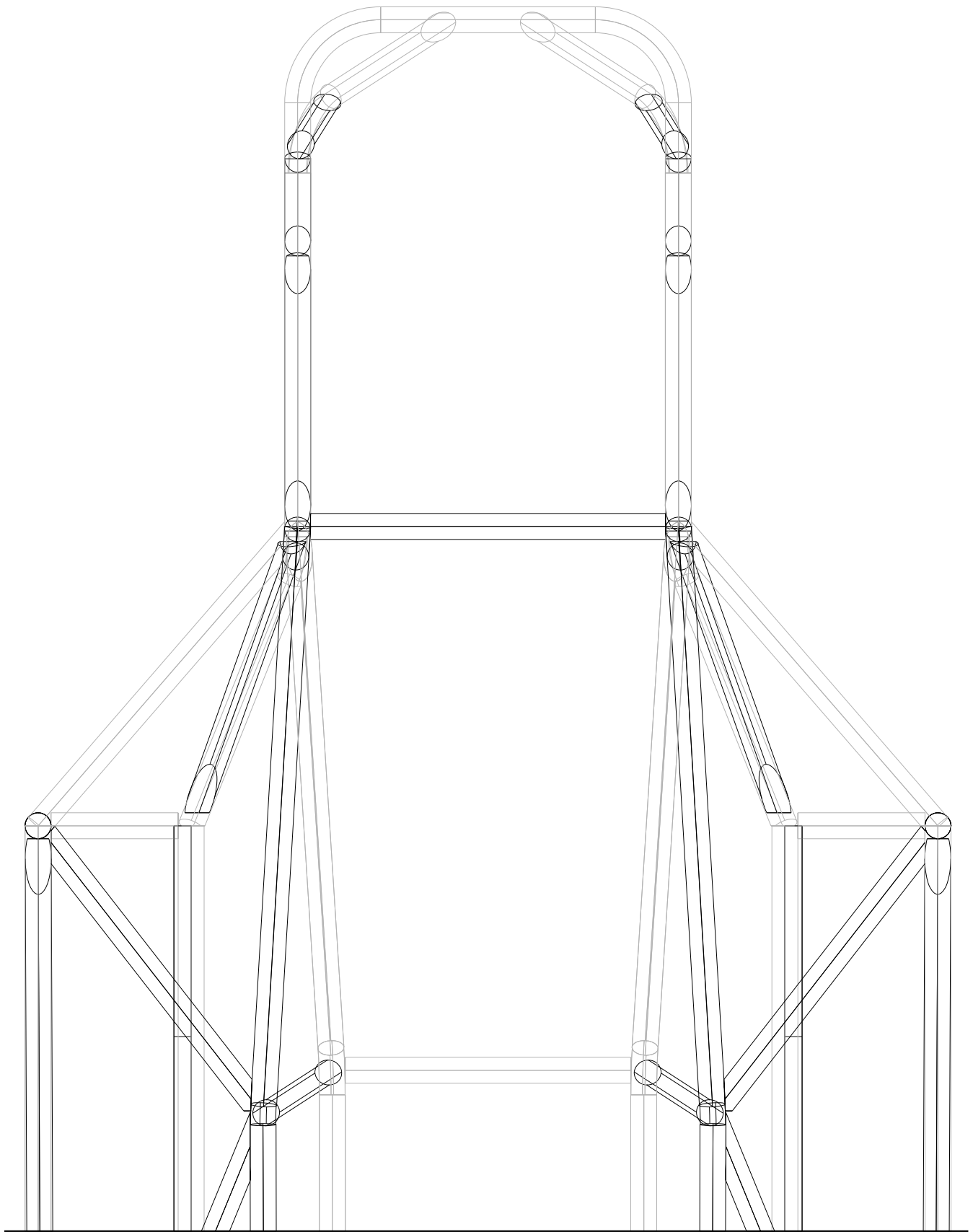

0 1
SCALE
1" = 1"

Project Name
F1 Chassis

TOP VIEW REAR

Figure 13

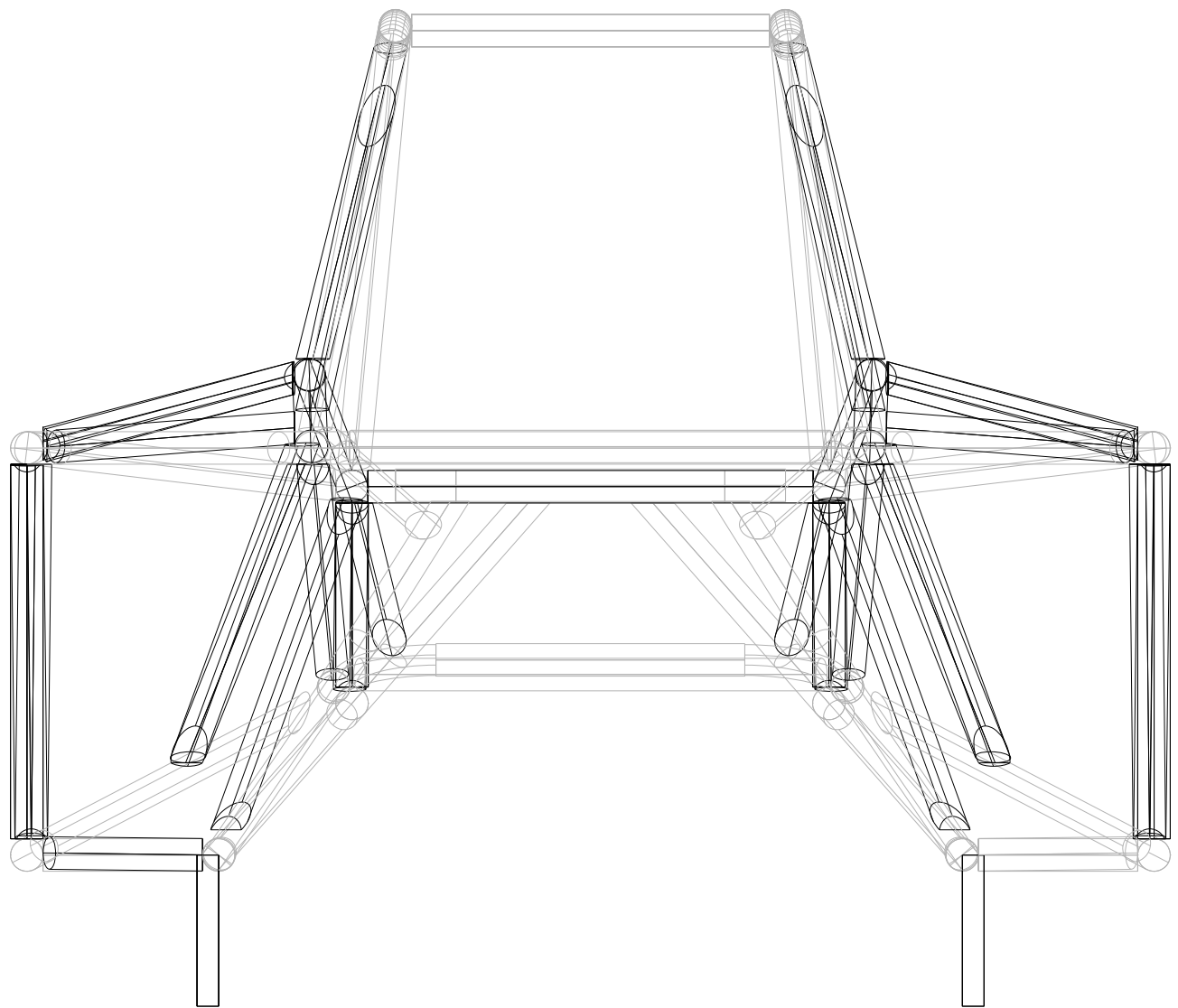

0 1
SCALE
1" = 1"

Project Name
F1 Chassis

FRONT VIEW

Figure 14

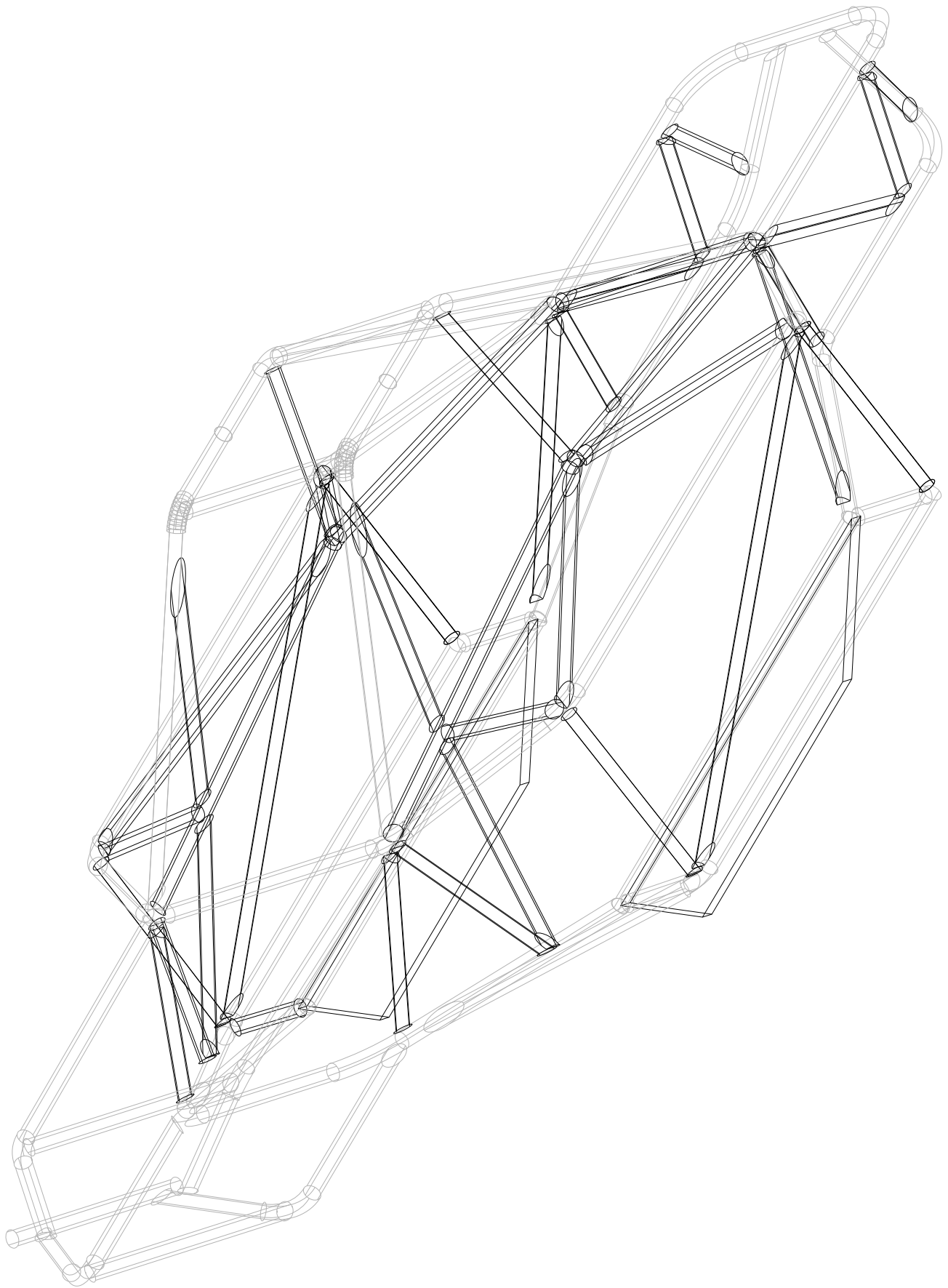

Project Name
F1 Chassis

ISOMETRIC-ISH

Figure 15